

# SPECIFICATION

## 1. PHYSICAL DIMENSION(UNIT: m/m):

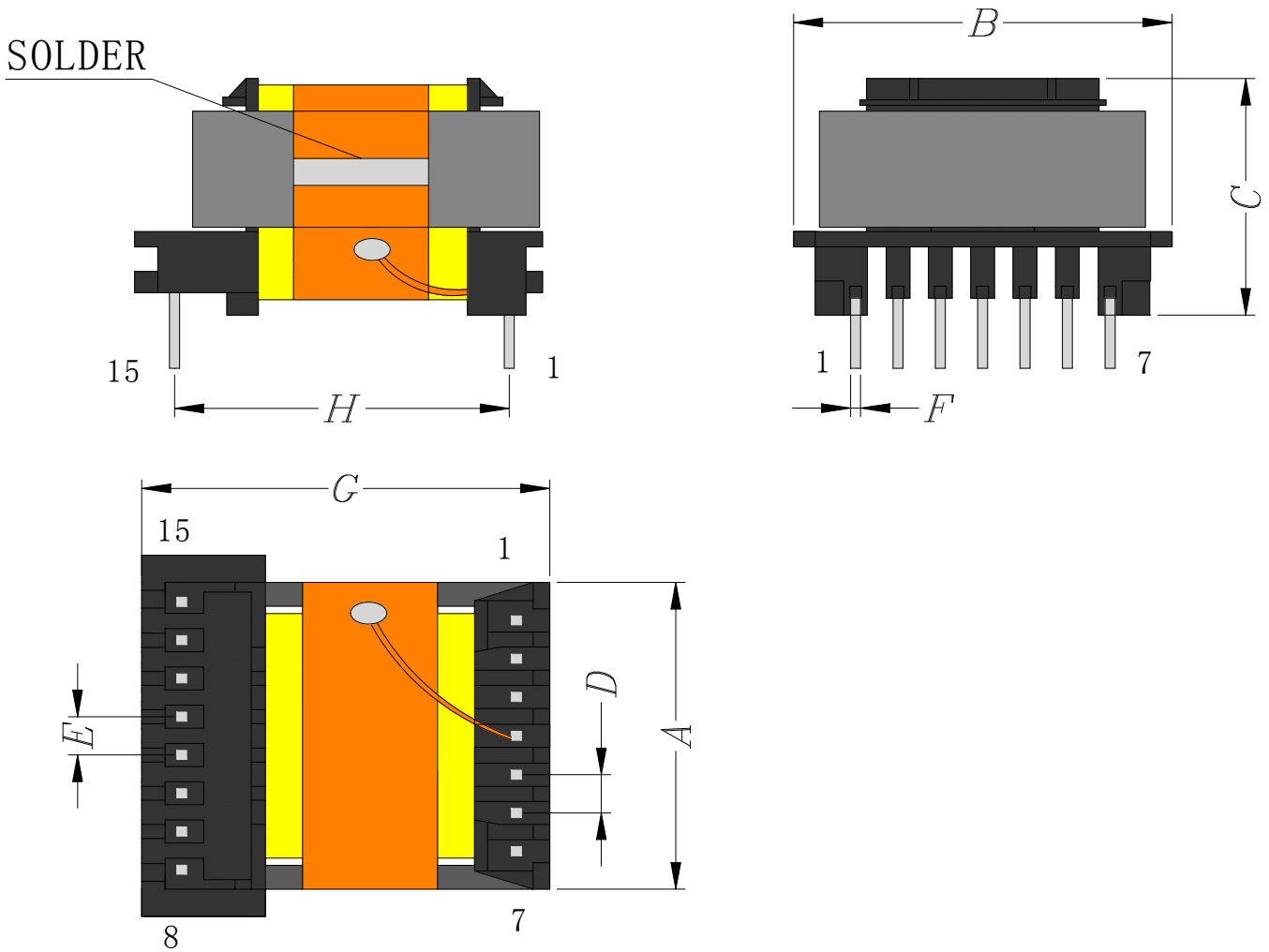

- ※DIMENSIONS WITHOUT TOLERANCE ARE APPROX
- ※DIMENSION DOES NOT INCLUDE SOLDER USED ONCOILS

**LEAD FREE**

\*All unused pins should be cut off

\*The copper foil (0.05t\*10.0mm)should be connected pin4 with 2UEWφ0.4mm

DIM	A	B	C	D	E	F	G	H				
	MAX	MAX	MAX	+/-0.2	+/-0.2	REF	MAX	+/-0.3				
SPEC	21.0	24.5	22.5	2.5	2.5	0.5	25.5	20.15				

	DESCRIPTION	TRANSFORMER
	Customer P/N	
	FERRIWO P/N	FWPTEE20H-851J-2

SPEC. NO.	PS-1001-013	PREPARED		APPROVED	
-----------	-------------	----------	--	----------	--

# SPECIFICATION

## 2.WINDING TABLE:

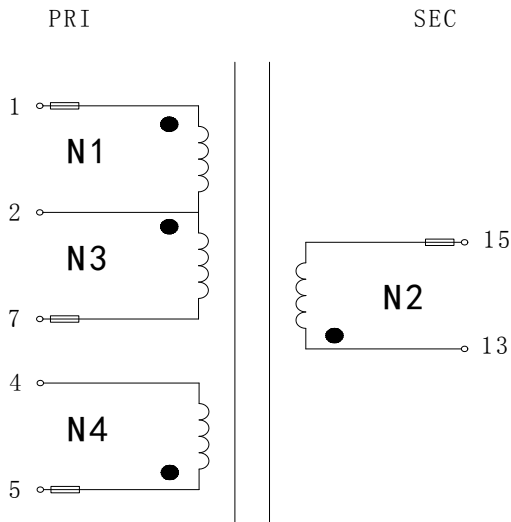

## 3.WINDING:

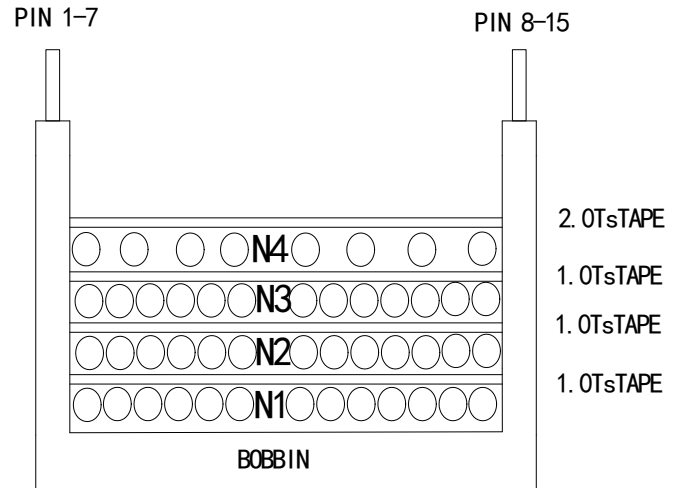

## 4.WINDING TABLE:

Winding NO.	Margin Tape	PIN	Wire & Wire Copper	Turns	Winding Type	Tape Layer	Tube
N1	0	1~2			Compact	1.0	S≈10mm
N2	0	13~15			Compact	1.0	F≈10mm
N3	0	2~7			Compact	1.0	F≈10mm
N4	0	5~4			Dispersed	2.0	S≈10mm

### NOTE:

- Pin 1 should be inside when the bobbin insert into the winding machine.
- Products should be vacuum impregnation
  - \*VARNISH RATIO: 1:1
  - \*VACUUM TIME: 15~20minutes
  - \*BAKED TEMPERATURE : 120°C±10°C, 1~1.5hours

**LEAD FREE**

DESCRIPTION	TRANSFORMER
Customer P/N	
FERRIWO P/N	FWPTEE20H-851J-2

SPEC. NO.	PS-1001-013	PREPARED	APPROVED
-----------	-------------	----------	----------

# SPECIFICATION

## 5. ELECTRONICAL CHARACTERISTIC:

TEST CONDITION : TEMPERATURE AT 25°C

HUMIDITY AT 65 ±5% RH

TEST ITEM	TEST CONDITION	RESULT
INDUCTANCE CH-3250	@10.0KHz,0.1V (1~7)	850uH±3%
LEAKAGE INDUCTANCE CH-3250	@10.0KHz,0.1V (1~7)	20uH MAX. (SHORT PIN13,15)
HI-POT TEST CH-9052	@ 2mA 3SEC (AC)	P<->S 3.0 KV; P、S<-> CORE 1.0KV;

**LEAD FREE**



DESCRIPTION

TRANSFORMER

Customer P/N

FERRIWO P/N

FWPTEE20H-851J-2

SPEC. NO.

PS-1001-013

PREPARED

APPROVED

# SPECIFICATION

## 6. MATERIAL LIST :

ITEM		MATERIAL	SUPPLIER OR MANUFACTURER	TEMPRATING
1	CORE	FW40 OR EQUIVALENT	HAINING FERRIWO ELECTRONICS CO., LTD.	
2	BOBBIN	PHENOLIC OR EQUIVALENT	SUMITOMO BAKELITE CO., LTD. UL NO E41429	150°C
3	WIRE	2UEW	PACIFIC ELECTRIC WIRE&CABLE(SHENZHEN) CO. LTD UL NO E84081	155°C
4	TRIPLE WIRE	TRIPLE. INSULATION. WIRE TRW(B)	GREAT LEOFLON INDUSTRIAL CO.,LTD UL NO E211989	130°C
5	TAPE	CT280	YAHUA STICKING TAPE CO.,LTD UL NO E165111	130°C
6	COPPER FOIL	0.05*10.0mm	YAHUA STICKING TAPE CO.,LTD	
7	VARNISH	R-1038	JOHN C DOLPH CO BC-346A UL NO E317427	130°C
8	FLUX	TF9100	LINAN GUITONG CHEMICAL TECHNICAL CO.,LTD	
9	TIN	Sn99.3Cu0.7	HAINING ZHUCHANG METAL FOIL CO;LTD	
10	EPOXY	E-500 (BLACK)	SUZHOU EATTO ELECTRONIC MATERIAL CO.,LTD UL NO E218090	130°C
11	TUBE	TEFLON TUBE	GREAT HOLDING INDUSTRIAL CO.,LTD UL NO E156256	200°C

**LEAD FREE**



DESCRIPTION

TRANSFORMER

Customer P/N

FERRIWO P/N

FWPTEE20H-851J-2

SPEC. NO.

PS-1001-013

PREPARED

APPROVED